

Stormwater Policy

Reference number:	POL 037
Approval date:	17 October 2022
Policy owner:	Director Infrastructure Services
Next review:	September 2025

This Policy sets out Council's requirements as the local authority for the management and regulation of stormwater.

Stormwater management can be broadly defined as managing the quantity and quality of stormwater runoff from a catchment with the aim of:

- minimising stormwater impacts on aquatic ecosystems;
- minimising flooding impacts; and
- utilising stormwater as a water resource.

This Policy is to be read in conjunction with the appropriate Council Stormwater Management Plan and Engineering Guidelines. This Policy does not cover every Council requirement relevant to Stormwater. Other policy documents referred to in this Policy provide additional information.

Purpose

The objectives of this Policy are:

- To identify Council's stormwater management plan,
- To identify the relevant regulations for the development requirements relating to stormwater,
- To enable the progressive delivery of improvements to the stormwater system for the greater community,

Scope

This Policy applies to all land within the Wagga Wagga City Council Local Government Area.

Policy Provisions

Responsibilities

The Manager of Operations, through the Director of Operations, is the responsible Officer for matters relating to this Stormwater Policy and the Public Stormwater System.

Reporting Requirements

Council must report annually on the Stormwater Management Plan. The reporting requirements will be in accordance with Clause 200A and 217 of the Local Government (General) Amendment (Stormwater) Regulation 2006.

Approval Arrangements

Approval is required under Section 68 of the Local Government Act (1993) for stormwater works.

Review procedures

This policy must be reviewed by the policy owner in accordance with the review schedule noted above.

General Provisions

Stormwater Management Plan

Sustainable stormwater management is the application of controls on stormwater to mitigate, manage and control changes to the natural water cycle, to protect environmental values and to protect human life and assets. The Stormwater Management Plan is the strategic planning and implementation document for the overall management of stormwater in the urban areas of the Wagga Wagga City Council local government area.

The Stormwater Management Plan has the following objectives:

- To implement a stormwater management plan that improves the total environment and water quality of receiving waterways into which stormwater is discharged;
- To protect property and infrastructure against flooding by waterways;
- To reduce instances of local flooding by surcharging stormwater under storm event conditions;
- To improve stormwater and receiving water quality through erosion control, maintenance, bank stabilisation, and removal of introduced vegetation;
- To reduce risks to the general public associated with stormwater and related infrastructure;
- To evaluate stormwater as a potential water resource for recovery and reuse within the urban environment;
- To define roles and responsibilities of management and staff with respect to stormwater management and operation;
- To outreach to the greater community to ensure that an understanding and appreciation of the total stormwater environment will encourage community acceptance and ownership of the stormwater system, and;
- To integrate Council management initiatives within other regulatory authority regional management plans.

Stormwater Management Levy

As per Councils Fees and Charges, Council charge an Annual Stormwater Levy which is intended to enable the progressive delivery of a range of fundamental improvements to the stormwater system for the greater community.

Some of the planned improvements include;

- improved water quality of receiving waterways into which stormwater is discharged
- reduced risk of localised flooding
- reduced risks to the general public associated with stormwater and related infrastructure
- increased stormwater harvesting and re-use

- education of the greater community to ensure that an understanding and appreciation of the total stormwater environment and encourage community acceptance and ownership of the stormwater system
- integration of stormwater management initiatives within other regulatory authority regional management plans.

The maintenance and operation of Council's stormwater system is largely funded from the general revenue stream and has been largely limited to the day to day operation of the system, with only minimal preventative maintenance, asset augmentation and renewal works being undertaken.

Recognising that the traditional funding mechanisms are limited and are not adequate to fund the maintenance of key public infrastructure in a serviceable and safe condition, the State Government amended the Local Government Act to encourage Council's to implement a program of major improvements for the management of stormwater through the introduction of a Stormwater Levy.

In accordance with the Local Government (General) Amendment (Stormwater) Regulation 2006 under the Local Government Act 1993, Councils are encouraged to implement a stormwater levy to facilitate works to improve the management of stormwater in their local area.

By implementing the charge, Wagga Wagga City Council will be able to raise funds in addition to the existing funds already allocated to stormwater management assisting Council with the delivery of critical works to improve water quality, reduce the risk of local flooding and optimise opportunities for stormwater harvesting.

Specific Provisions

Engineering Guidelines for Subdivisions and Developments

All development has an impact on the behaviour of stormwater through the addition of impervious surfaces, diversions and drainage and through changes to water quality.

The Engineering Guidelines for Subdivisions and Developments have been compiled to outline Council's general procedures and practices in respect of the engineering and technical requirements for subdivision and development of land within the Wagga Wagga City Council local government area.

Easements

Council shall require easements for drainage to be created over all new stormwater mains not in road reserves. In the case of any subdivision, the easements for sewer and drainage shall be created and registered, at the developers cost as part of the development.

Stormwater Contribution Scheme

That as a matter of Policy, Council when considering development applications for approval require developers (where there is any impact on Council's stormwater drainage system) to obtain compliance certificates under Division 5 of Part 2 of Chapter 6 of the Water Management Act 2000(as required under Section 64 of the Local Government Act 1993) prior to the release of subdivision or approval of the application.

Such certificates are only to be issued following receipt of the required contribution. The level of contribution is defined by the adopted Development Servicing Plan(s) as adopted by Council. Council will make adopted Development Servicing Plan(s) available for public inspection.

Flood Management

Riverine Flooding

Council will endeavor to minimize impacts of riverine flooding and flood liability on individual owners and occupiers of flood-prone land, and to reduce private and public losses resulting from floods. Riverine flooding is managed in accordance with NSW Floodplain Development Manual: The Management of Flood Liable Land 2005.

Wagga Wagga City's Main Levee has been upgraded to provide flood protection for the city. North Wagga's levee currently provides flooding protection for the suburb. Other levees are in Uranquinty, Tarcutta, Gumly Gumly and Oura.

Overland Flood Flows

Overland flooding is managed in accordance with NSW Floodplain Development Manual: The Management of Flood Liable Land.

Attachment 1 - Encumbrance Brochure and Application Form

Building Near Sewer or Stormwater Lines

Sewer & Stormwater Mains Protection

The public sewer and stormwater mains are assets, which the Local Council is responsible for

The mains consist of major and minor pipelines, property connection points, and a variety of access chambers. Some stormwater is carried in open drains and in some cases, sewer is carried in pressure pipelines.

The Problem

Sewer and stormwater main have high risks; and faults in these mains can cause substantial damage

Council needs to access all parts of the mains in order to ensure the health and safety of its public.

Access for inspection, maintenance and long-term renewal is critical, particularly at connection and access points.

This means that buildings should not normally be developed over, or too close to sewer and stormwater mains. Refer to 'Development Affecting Mains'.

The Solution

Nearly every landowner will have some part of the sewer and stormwater mains located within their property. Council recognises that in some cases the inconvenience of such restrictions make it worthwhile for owners to fund alterations to the mains to allow the works to proceed while managing the risk. Council's stormwater policy has been developed to address these cases.

We aim to help landowners maximise the land use and enjoyment of their property, while maintaining the integrity of the sewer and stormwater mains. We can provide accurate, helpful and specific information to you and aid you in the construction process.

Council also pursues continual advances in pipe and construction technology to make new mains installation as reliable as possible, minimising the future need to carry out the work on individual properties.

What is an encumbrance?

In Council's policy, **an encumbrance refers to anything that hinders access to or may damage any part of the public sewer or stormwater network.**

Some examples of potential encumbrance include:

- Sheds, carports and pergolas
- Retaining walls, barbeques, stone walls
- Pools (in ground and above ground), storage tanks
- Underground utilities (water, gas, power)
- Fences, paving
- Houses, habitable rooms
- Landscaping that significantly changes the ground level

Private sewer and stormwater pipes (those that serve only the owner's property) are not subject to protection by this policy. However, plumbing approvals may impose certain restrictions which are covered by the normal council approvals process.

Refer to the *How to Read a Sewer and Stormwater Diagram* for an explanation of property sewer and stormwater typical layout diagram.

Encumbrance Zones

There are two types of encumbrance zones.

Zones of loading influence are areas on the ground which extends either side of the pipe's location. Structures built in this zone may transmit load through the ground onto the pipe, increasing the chance of pipe failure. Sinking of the original trench or scouring caused by pipe failure may undermine any structure built within the zone.

The standard zone of influence is [depth to pipe base + 300mm] either side of the pipe centre line. The standard (conservative) zone of influence is based on a 45-degree angle of repose (see the diagram over the page). A smaller zone of influence may be considered if an accredited geotechnical engineer provides advice on the suitable angle of repose.

Zones of clearance are used to provide sufficient room for repairs and/or replacement of parts of the system. Unauthorized structures in this zone may endanger council employees, restrict critical repairs or themselves be damaged or demolished at the owner's expense. Usually, council requires a 2.5m strip for access to the pipe, including at least 0.6m clearance on each side.

Council **Easements** have been created in newer properties to make property owners aware of the areas of building restrictions.

How will this affect my plans?

The main factors in determining what system encumbrance may be allowed are:

The type of proposed structure; easily demountable structures are more likely to be allowed.

The type and condition of the sewer or stormwater main proposed to be encumbered; Main trunk lines serving large numbers of properties will be subject to greater protection than minor lines serving few houses. Pipes that may sometimes overflow are also given greater protection. The age and condition of the pipe will also be considered. No access chambers may be encumbered.

The first thing you need to know is the locations and type of sewer or stormwater mains located in your property. Council has a **diagram of the property drainage pipes** for many properties in Wagga. An example is provided over the page.

The next thing to do is to look up the "Developments Affecting Mains". This will explain if you are required to apply for conditional approval from Council before building works can proceed.

Existing encumbrances

Some existing buildings or other structures may already encumber sewer and stormwater mains. Any replacement or extension of such items will not be permitted by Council. You will need to make a new application to encumber a council asset as outlined in this brochure.

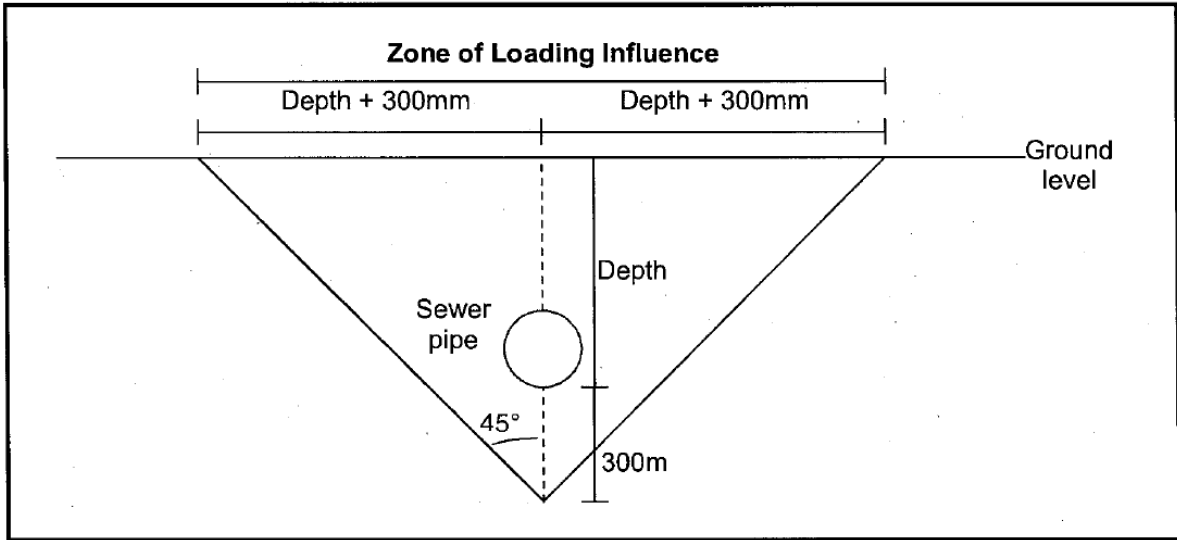
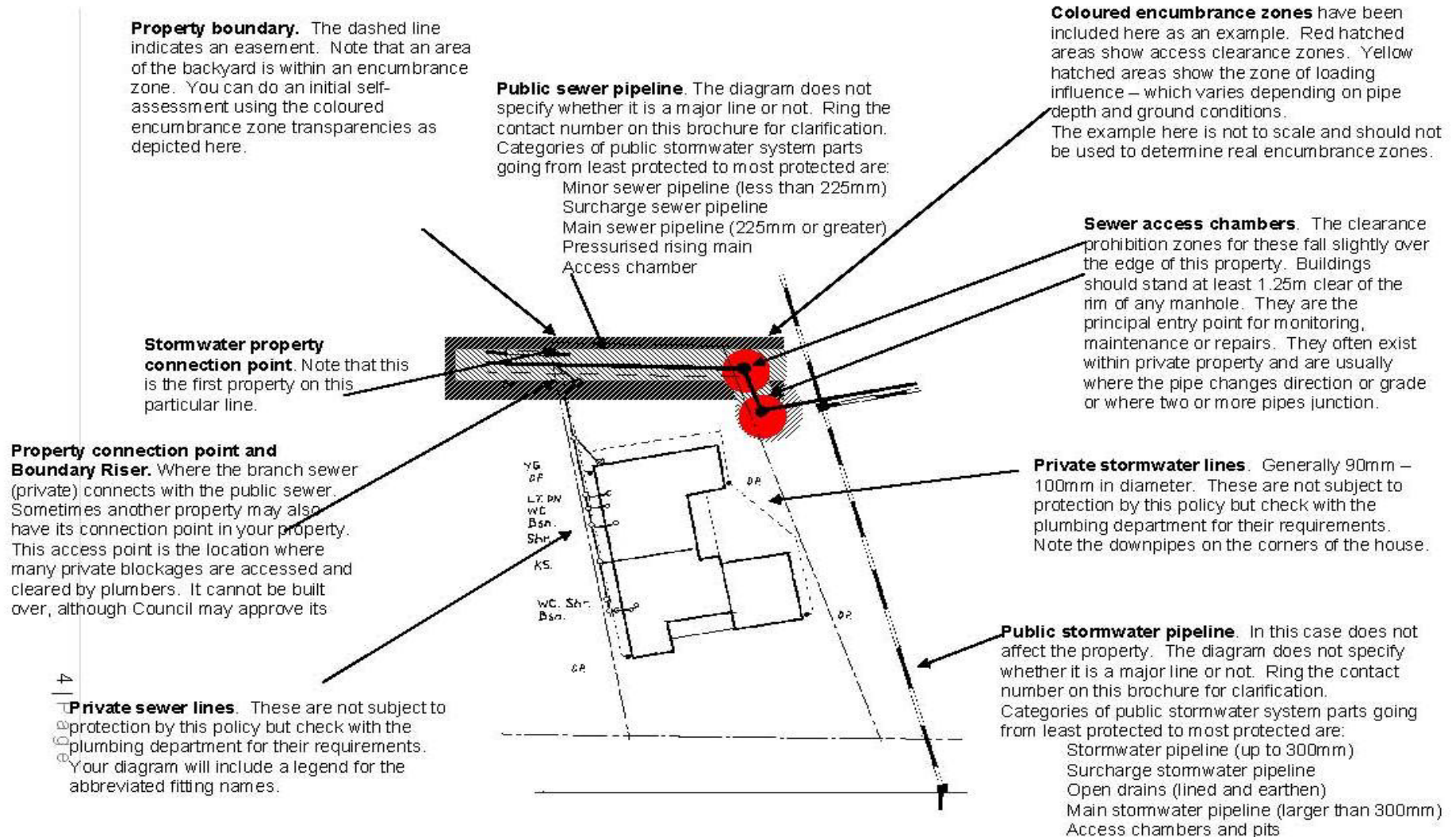

Diagram showing the Encumbrance Zone of Loading Influence

HOW TO READ A SEWER AND STORMWATER DIAGRAM



General Approval Conditions

Financial

If a main is required to be upgraded or relocated to accommodate a development this will be at full cost to the applicant/developer.

The applicant/developer will also need to fully fund any further works required for the creation of the encumbrance, such as strengthened foundations or alteration of existing house plumbing.

The applicant/developer will need to meet any administrative costs incurred by the Council in establishing the encumbrance agreement. In most cases this is covered by the application fee.

In cases of significant structures such as buildings, the applicant/developer will be required to pay for and organize the establishment of a positive covenant (under section 88E of the Conveyancing Act 1919) which indemnifies the council against all claims arising from the existence of an encumbrance within the zone of influence of the system. This is to ensure that any future purchaser or other interested party will be notified of the existence of the encumbrance and any conditions placed upon it.

Agreements

Any approval of an encumbrance of a sewer or stormwater system will require that the owner acknowledge that Council will not be held responsible for any damage that could result from the encumbrance. This is to indemnify Council against all claims arising from the existence of an encumbrance within the zone of influence of the system.

The owner must also guarantee access to the line for maintenance work at any time. Damage caused to the development by such maintenance shall be at the owner's expense.

Council Inspections and Approvals

Council will place certain building requirements on any approved encumbrance. These conditions will be added to any standard development approval conditions. The overall development approval issued by Council will include these conditions and will nominate a program of mandatory inspections.

You must not commence any construction until you have obtained a formal construction certificate.

Developments Affecting Mains

Not Allowed to Encumber Mains and Easements

- Habitable Rooms (e.g. Bedrooms, Living rooms, Offices).
- Carport attached to a building with a contiguous roof
- Swimming Pools and Spas (above Ground and Inground)
- Enclosed and Roofed Pergolas.
- Storage Tanks

Allowable with Conditional Approval (including an encumbrance fee and positive covenant)

- Large Sheds (more than 15m²)
- Garages
- Carport (non-contiguous roof)
- Free standing open pergolas
- Retaining Wall with footings
- Barbeques
- Swimming pool decks

Allowable with Conditional Approval (with no encumbrance fee and positive covenant)

- Small garden sheds (less than 3m x 5m with no floor)
- Swimming Pool Fences, Pumps and Filters
- Retaining Walls 600mm minimum height with no footings
- Driveways
- Concrete slabs <70mm thickness

Where to Now??

This brochure has been designed to point you in the right direction. You will find that you will get assistance in interpreting this brochure from the following people:

- Building and pool suppliers
- Kit shed and pergola suppliers
- Real Estate agents
- Solicitors
- Land developers, planners, trades people, and engineers
- You can also deal directly with Council if you choose

Sewer diagrams: Visit or ring the Council offices to obtain a copy of your property's sewer and stormwater diagram. You must be the owner of the property or have the authorization for the owner. A fee applies.

While you are at the Council offices you can be provided with additional information on any sewer or stormwater mains and easements located within your property and what limitations apply.

It is better if you can avoid developing over sewer and stormwater mains and easements. There is less expense involved for the developer and access to Council sewer and stormwater mains is maintained.

All applications are considered on their own merits, and any engineering solutions available to manage the encumbrance. Any variations from the normal conditions will be limited to that specific approval.

General Enquires to 1300 292 442

NOTE: Copies of all Policies are available on Councils website www.wagga.nsw.gov.au or can be viewed upon request at the Civic Centre.

**Application for a Determination regarding a Proposal to
Encumber a Service Line and/or Easement
(as per Council Sewer Policy POL036 and stormwater Policy POL037)**

General Manager
Wagga Wagga City Council
PO BOX 20
WAGGA WAGGA NSW 2650

Approval in terms of Council's Sewer Policy POL036 and Stormwater Policy POL037 is sought to encumber a service and/or easement at the following property:

Site Address: _____

If the necessary approval is granted, I will ensure that the building is appropriately designed and built in accordance with any conditions issues in the acceptance. I acknowledge that Council has the right of access to the line for maintenance etc. and that council can't be held responsible for any problems or damage that results from the fact that the development is over or adjacent to the main.

Applicants Name: _____

Owner Builder Developer

Address: _____

Phone: _____ Signature: _____

Owners Name: _____ *(if different from applicant)*

Additional information required, please turn over

The following is required to be included with the application.

Is this structure already in place over the main/easement? _____

Description of the structure(s) _____

What materials are used in the structure? _____

What are the dimensions of the structure(s) e.g. length, width, height?

Does the structure have a floor? What is the floor made out of? How thick is the floor?

Please Attach:

a) a site plan showing your proposed works, their size and position relative to the property boundaries and easements.

b) If available, architectural plans and detailed structural designs of footings

d) Any other information that you think may assist your application

Privacy and personal information protection notice: The personal information provided is collected for the purpose of processing this application. Access is limited to Council employees and other authorised persons. Supply of the personal information is legally required and non-supply could cause delay or inability to proceed in the processing of this form. The personal information will be stored in council's system.

An application fee is payable at the Wagga Wagga Civic Centre and will be charged as per the current Revenue and Pricing Policy

OFFICE USE ONLY

<i>Customer Service Only to Complete</i>		
Date Rec:	Rec No:	BOS:
Lot:	DP:	CSO:

Legislative Context

- Plumbing Code of Australia 2012
- Australian and New Zealand Standard Plumbing and drainage AS/NZS 3500:2015
- Local Government Act 1993
- Section 496A of the Local Government Act 1993
- Local Government (Water Services) Regulation 2005 made by the Local Government (General) Amendment (Stormwater) Regulation 2006

Related Documents

- Stormwater Management Plan
- Engineering Guidelines for Subdivisions and Developments
- Water Services Association of Australia
- Department of Local Government Stormwater Management Service Charge Guidelines 2006
- Council's Fees and Charges

Definitions

Term	Definition
Stormwater	is a generic term for rainfall that lands on the Earth's surface and becomes runoff, representing a significant proportion of the natural water cycle
Council	Wagga Wagga City Council (WWCC)
Stormwater Management Plan	Wagga Wagga City Council's management plan for stormwater

Revision History

Revision number	Council resolution	Council meeting date
1	Res No: 02/1141	28 October 2002
2	Res No: 04/243	23rd August 2004
3	Res No: 09/077	27 July 2009
4	Res No: 13/187	29 July 2013
5	Res No: 13/224.1	26 August 2013
6	Res No: 17/279	28 August 2017
7	Res No: 22/354	17 October 2022